



Gear Series **GB5P**

Spur Reduction Gearhead - 5 Kg-Cm



Design

Gearhead GB5P, the most popular gearhead, is a multi step gear box with all polyacetal gears which rotate on steel spindles which are polished to a mirror-finish and introduced between metal plates with a plastic frame. All bearings are permanently lubricated and therefore require no maintenance. Motor is attached to the gear box by means of spring clip. Thicker shafts (\varnothing 6-7mm) mounted in robust bushings (\varnothing 12mm) are available (GB5PS). Similarly the gears at the output end can be metal (GB5PH) with thick shafts & robust bushings (GB5PHS). Sintered gears variant also possible (GB5Si) GB5P can also be combined with small DC Motors. To achieve higher gear torque, GB5P can be mounted on GB4. Linear drives also possible with small sized motors (\varnothing < 36 mm).

Standard Data

Gear Torque	kg-cm	5
Combination with Mechtex motors		MT0, MT6, MTR/S3a/3b, MTR/S-5, MTR/S4a/4b and small DC motors
Mounting		any position
Weight	gm	60
Axial thrust	kg	2
Radial torque	kg	6
Lateral torque	kg-cm	6
Slipping clutches / free wheel		Not available; only available in GB5PH
Output shafts	\varnothing	3.175, 4.00, 4.76, 5.00, 6.00, 6.35 & 7.00 (others on request)
Ambient temperature operation	$^{\circ}$ C	-15 ... +55

Transmission ratios

25/6	5	25/3	10	25/2	15	50/3	125/6	25	30	125/4	100/3	75/2
125/3	45	50	60	125/2	75	250/3	100	125/2	120	125	135	1125/8
150	500/3	375/2	200	250	2500/9	300	375	1250/3	450	500	600	625
750	900	1875/2	1000	1125	1200	1250	1500	1800	1875	2250	2500	3000
3600	3750	4500	5000	6000	other ratios & higher transmission ratio also available							

Dimensional Drawing

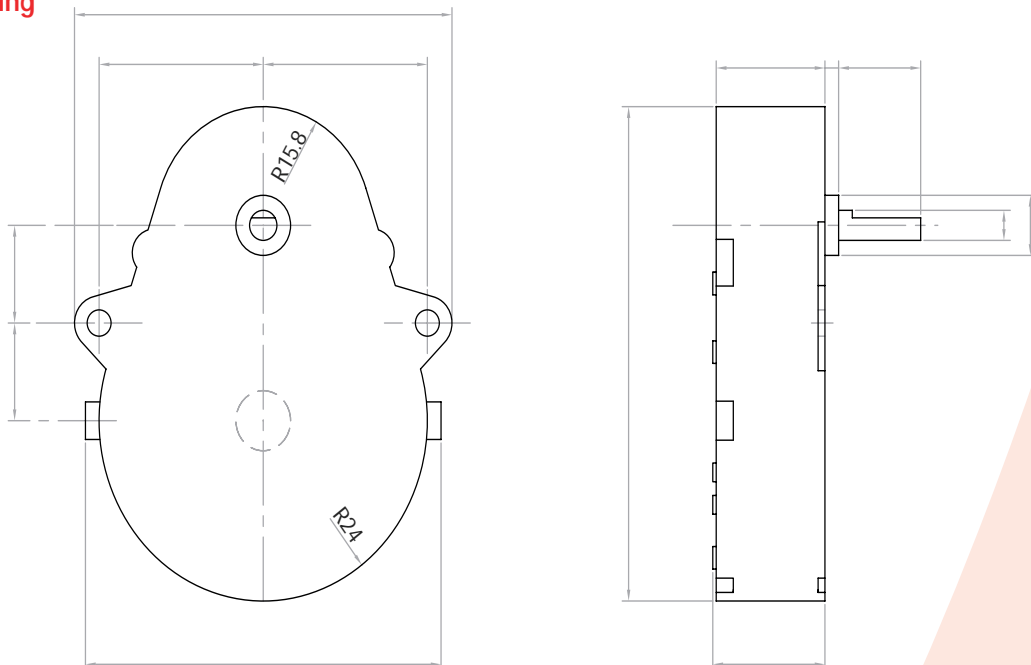



Gear Series GB5P

Spur Reduction Gearhead - 5 Kg-Cm

Torque/Transmission ratio/life Graph

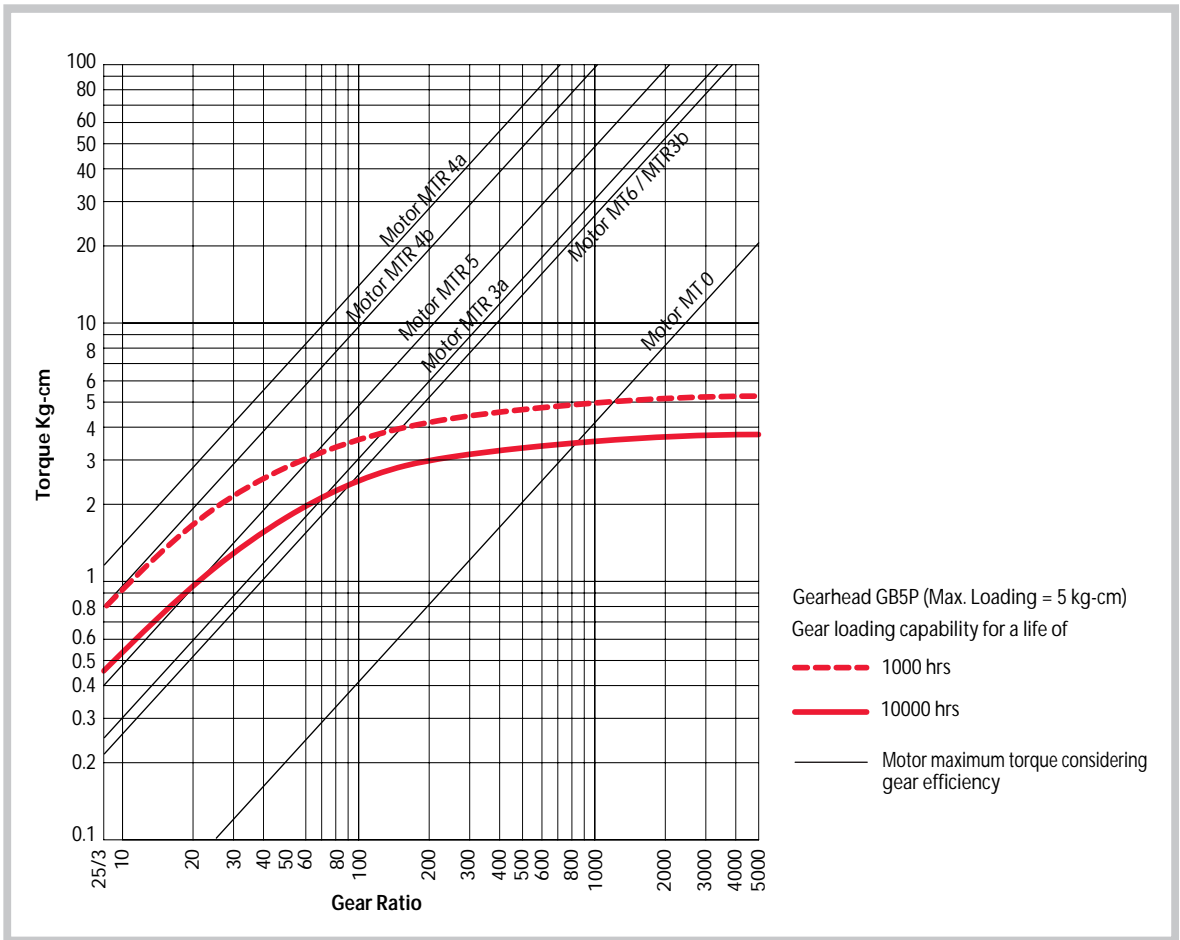

Drawings

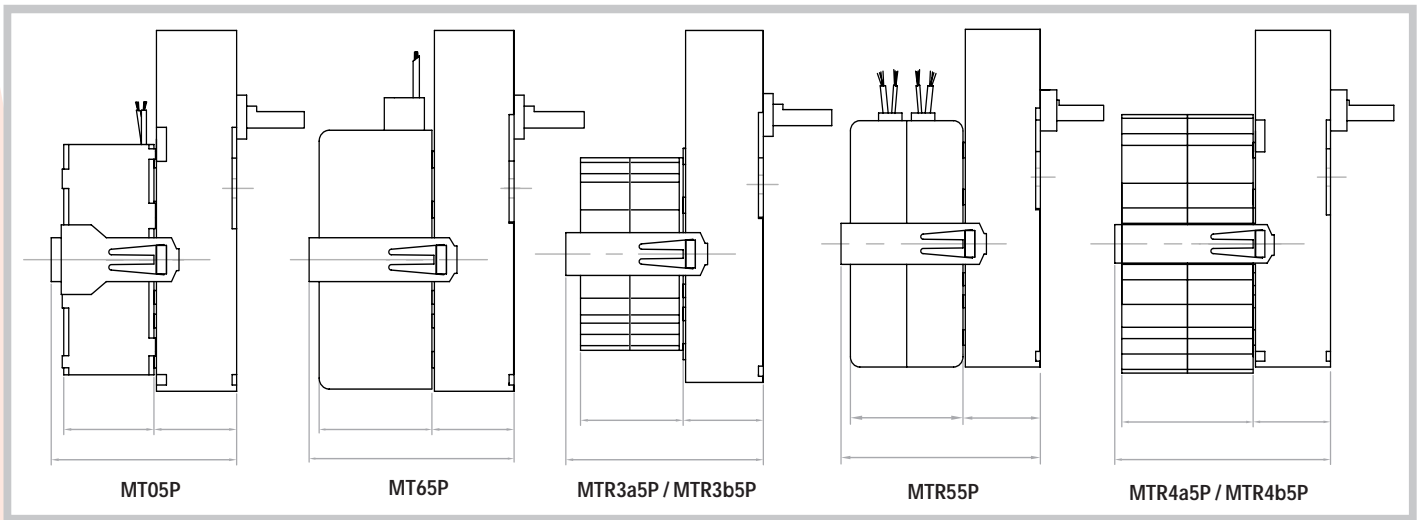

Photographs

