

Motor Series **MTR3b**

Reversible Synchronous Motor - 500 RPM



Application

Recorders, Instrumentation, Diamond machinery, Valve Actuators, Light displays, Textile machinery, Medical equipment, Air conditioning & refrigeration, Dampers, Peristaltic Pumps, Dosing Pumps, Vending machines CCTV Camera positioning, any timing and positioning Application.

Design

MTR3b reversing synchronous motor is of the permanent magnet type with two stator windings, for single phase AC 50/60 Hz. Phase displacement of the excitation current is achieved by connecting a capacitor in series with one of the stator windings. The sense of rotation is determined by the resulting circular rotating field. Electrical reversal of the sense of rotation is effected by means of a single-pole changeover switch.

The 12 pole rotor which has a steel shaft polished to a mirror-finish rotates in sintered bronze bearings.

Motor can be provided with Mounting plate/Screw clip for fixing.

Standard Data

Motor type		Reversible synchronous
Ambient temperature operation	°C	-15...+55
Ambient temperature storage	°C	-20...+100
Thermal class	°C	105
Electrical Enclosure	IP	40
Connections		Flexible Leads 26 AWG, 200mm length; ends stripped
Sense of rotation		Indicated by lead colour (red-CW & black ACW)
Life expectancy		3 Years in continuous operation
Mounting		any position
HVT		2.0 KV (motor voltage>40V) or 0.6 KV (motor voltage<40V) for 1 min.
Weight	g	65
Rotor stalling		Motor can be stopped when voltage is applied, without being overheated
Rotor shaft		Hardened steel, ground and polished
Bearings		Sintered bronze, self-lubricating
External dimensions		dia. 36 x 21 mm

Technical data

Standard Motor Voltages(V _N)	V	12	24	48	110	220*	240*
Operation capacitor(50 Hz)C _N	µF/VAC	15/ 20	3.9/ 50	1.0/ 100	0.18/ 200	With add on units	
Operation capacitor (60Hz) C _N	µF/VAC	15/ 20	3.9/ 50	1.0/ 100	0.18/ 200		
Lead colour (V _N)		Grey	Blue	Brown	White	Yellow	
Tolerance of voltage	%	-10...+15% of rated voltage					
Duty cycle	%	100					
Rated frequency	Hz	50			60		
Power output at rated voltage	W	0.23			0.25		
Speed	rpm	500			600		
Running torque at rated voltage	N-cm	0.45			0.4		
Power consumption at rated voltage	W	1.5			1.5		
Detent Torque	N-cm	0.13					

Connection Diagram

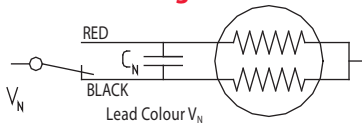

Add on units for 220* & 240* V

220.240 V (V_N motor 110V)

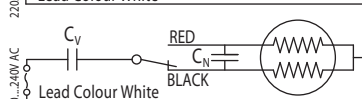
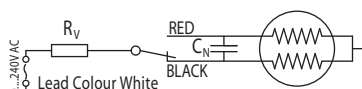

Unit	220V	240V
R _V (1.5W) 50/60Hz	8.2 KΩ	8.2 KΩ
C _N (200 VAC) 50 Hz	0.22 F	0.22 F
C _N (200 VAC) 60 Hz	0.18 F	0.18 F

Motor Drawing

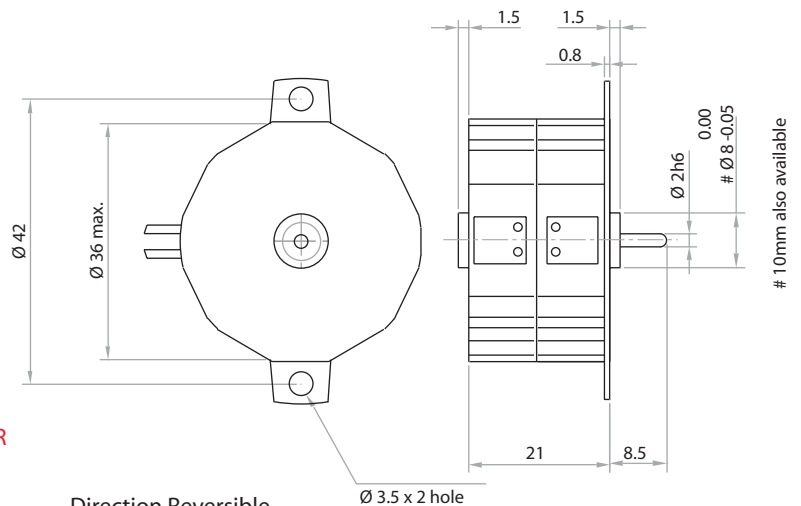

Ordering Data (eg.)

